

---

# **BISOMAC210**

## **Electric Traction Hoist**

### **Operator's Manual**

**Model: BISOMAC210-1508U**

---

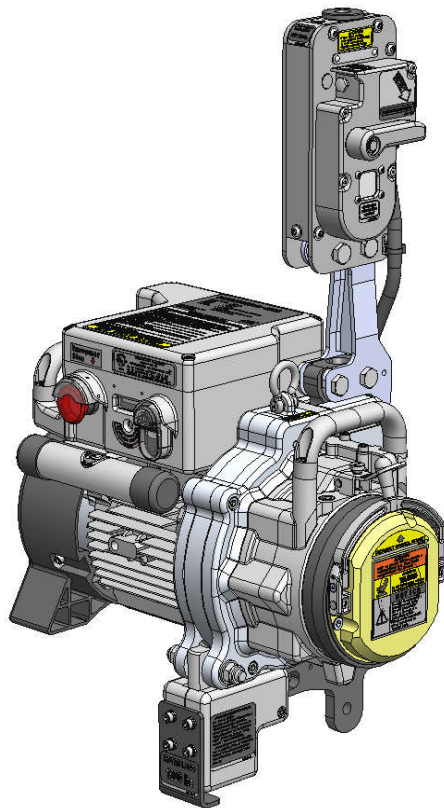

#### **WARNING**

**Read manual before operating this Hoist. Failure to follow the safety precautions and instructions in this manual could result in serious injury, death or damage to the Hoist.**

**NIHON BISOH CO., LTD.**

 **WARNING**

- All operators must read and understand this manual before operating this equipment. Failure to follow the safety precaution and instruction in this manual could result in serious injury, death or property damage.
- All operators must be fully trained in the use of the equipment including its safety features.
- Each day before the equipment is used, the operator must carry out the Daily Tests and Inspections described in Section 7 of this manual to confirm that equipment is in a normal and safe operating condition.
- Only authorized and physically fit operators shall operate the equipment.
- Any operation in violation of these instructions is at the operator's own risk and may result in serious injuries.
- Ask for a replacement if this manual is ever lost or becomes illegible.
- Only use spare parts and steel wire rope provided and/or specified by NIHON BISOH CO., LTD.
- Use only machinery or incorporated component, which has been declared to be in conformity with UL1323 and national implementing.

**MANUFACTURER: NIHON BISOH CO., LTD.**



## Contents

<b>0. READ BEFORE USING BISOMAC210 TRACTION HOIST</b>	<b>1</b>
<b>1. FOR SAFE USE</b>	<b>3</b>
1.1 General	3
1.2 Maintenance	3
1.3 Categories of Safety Instructions	4
<b>2. SPECIFICATIONS</b>	<b>11</b>
2.1 BISOMAC210 TRACTION HOIST	11
2.2 WIRE ROPE	12
2.3 POWER CABLE	12
<b>3. FUNCTION AND DESCRIPTION OF EACH COMPONENT</b>	<b>13</b>
3.1 BISOMAC210 TRACTION HOIST	13
3.2 Overspeed Detection Device	16
3.3 Overload Detection Device	17
<b>4. WORK ENVIRONMENT</b>	<b>18</b>
<b>5. SET UP INSTRUCTIONS</b>	<b>19</b>
<b>STEP 1</b> Installation of Safety Devices to the Hoist	<b>23</b>
<b>STEP 2</b> Connection of Power Supply	<b>25</b>
<b>STEP 3</b> Mounting BISOMAC210 to the platform	<b>26</b>
<b>STEP 4</b> Main Wire Rope Reeving	<b>27</b>
<b>STEP 5</b> Confirming Operation of Overspeed Detection Device	<b>27</b>
<b>STEP 6</b> Perform of Daily Inspection	<b>28</b>
<b>6. OPERATION / HANDLING METHODS</b>	<b>29</b>
6.1 Carrying BISOMAC210	31
6.2 Operation and Use of Emergency Stop	31
6.3 Emergency Descent Lever	32
<b>7. DAILY TESTS AND INSPECTIONS</b>	<b>33</b>
7.1 Test Procedure of Rigging	35
7.2 Test Procedure of Wire Rope	36
7.3 Test Procedures for Lifting and Use of Emergency Stop	37
7.4 Test Procedures for Controlled Descent Device	37
7.5 Test Procedures for Overspeed Detection Device	38
<b>8. PERIODIC INSPECTIONS</b>	<b>39</b>
<b>9. TROUBLESHOOTING AT JOB SITE</b>	<b>40</b>
Attachment	
Electric Control and Electric Parts Function	

## 0. READ BEFORE USING BISOMAC210 TRACTION HOIST

This Operator's Manual had been prepared for the safe and proper operation of the **BISOMAC210 Electric Traction Hoist** (referred to as "BISOMAC210"). To understand the usage of the BISOMAC210 Traction Hoist, please refer to the following explanation and system compositions. It is operator's responsibility to be sure that this hoist is used safely and properly.

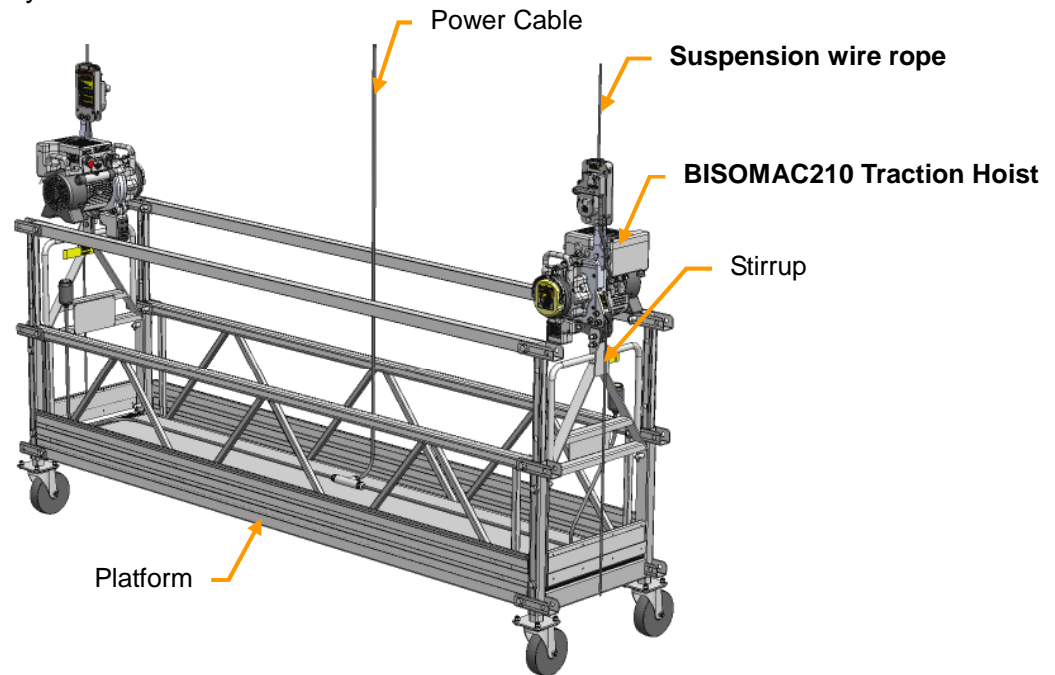

### 1) Power Supply to the equipment must be fitted with

- a) Main switch

NOTE: Main switch with key-lock or Junction Box with key-lock shall be provided.

- b) Residual current device (or earth leakage circuit breaker) of 30 mA.
- c) Overcurrent protective device (automatic fuse Type C)

Note: Check that the specifications of the electrical supply cable match the power requirement of the platform and will avoid a voltage drop due to cable length.

### 2) Weather conditions

Temperature range:	14° F (-10° C) and 104° F (+40° C)
Contaminants:	Degree of protection IP54
Altitude:	less than 3,280 ft (1,000 meter)

### 3) Precautions prior to use

- a) Before using the equipment, operators must carry out the Daily Tests and Inspections described in Section 7 of this manual and make sure that the equipment is in normal working condition.
- b) Before using the equipment, operators must confirm that there are no obstacles along the movement of the platform.

- c) Before use the equipment, the suspension system must be checked to ensure the stability of the platform at all times.
- d) In case the area below the platform is open to the public, preventive measures have to be taken to safeguard the people below (e.g. barriers, roof protected walkways, etc.)
- e) All hazards related to the platform encountering obstructions are not completely covered by the platform's safety devices. The operator shall check for obstructions along the travel of the platform.
- f) The Overload Protection may not protect the platform in all configurations. The operator must check that the loading of the platform does not exceed the rated load indicated on the nameplate.
- g) An area on the platform must be available to allow operators to operate the hoist safely.
- h) Use approved personnel harnesses, lanyards, rope grabs, and independent lifelines at all times.

#### **4) Precautions during use**

- a) The operators must stop working with the equipment and notify the supervisor if faults, damage to the equipment or other circumstances may jeopardize safety.
- b) A suitable communication between the operator and the supervisor is recommended.
- c) When you leave a platform, shut off the power supply at the main switch and lock it so that no one else can operate it.
- d) When the hoist stops for more than 30 minutes in low temperature, the hoist can be difficult to rise. In that case, allow the hoist 30 seconds to idle or lower the hoist before trying to use.

#### **5) Forbidden Uses**

- The BISOMAC210 is not allowed to use for any other purpose than for lifting and lowering a platform.
- Two units or more of the BISOMAC210 are not allowed to use on one wire rope.
- The BISOMAC210 is not allowed to use by inserting a wire rope into the wire rope outlet.
- Do not tight end of suspension wire rope when using BISOMAC210.
- Do not apply more than 45 lbs discharge resistance to the end of wire rope.
- The BISOMAC210 is not allowed to use in water.
- The BISOMAC210 is not allowed to use as a crane for lifting and lowering materials.
- The BISOMAC210 is not allowed to use as a lifting device of a permanent elevator.
- The BISOMAC210 is not allowed to use as a horizontally pulling traction device.
- The BISOMAC210 is not allowed to use as a medical traction device.

## 1. FOR SAFE USE

### 1.1 General

This Operator's Manual is applicable to the BISOMAC210 Electric Traction Hoist manufactured by Nihon Bisoh Co., Ltd. The BISOMAC210 consists with Hoist Device (referred to as "Hoist"), Overspeed Detection Device and Overload Detection Device.

This Operator's Manual (referred to as "Manual") had been prepared for safe and proper operation of the BISOMAC210 1-phase electric power specification.

1. Read and understand this manual fully before using the BISOMAC210.
2. This BISOMAC210 is designed for vertical ascent and descent of personnel-carrying suspended platforms. The BISOMAC210 should only be used for this purpose.
3. All operators must be fully trained in the use of the equipment including its safety features.
4. Daily Tests and Inspections described in Section 7 must be performed at the start of each work shift.
5. Use Section 9 troubleshooting guide in this manual to solve problems that may develop with the BISOMAC210. Understand the problem before attempting to solve it.

It is very important that anyone using the BISOMAC210 determine for themselves whether the BISOMAC210 is safe. You must be familiar with the operating characteristics of the BISOMAC210. You must understand how the BISOMAC210 will interact with other equipments and it is very important to confirm safety of the whole platform. You must also be certain not to jeopardize yourself or others, or cause damage to the surroundings, or the BISOMAC210.

### 1.2 Maintenance

Handling, maintenance, inspections and repairs of the following products must be performed by trained personnel only who have been read the BISOMAC210 Maintenance Manuals (another sheet).



BISOMAC210 consists of:

- 1) Hoist Device
- 2) Overspeed Detection Device
- 3) Overload Detection Device.

There are individual maintenance manuals for the hoist and safety devices.

### 1.3 Categories of Safety Instructions

In this operator's manual, the safety instructions are classified according to risk levels.

Symbol	Code word	Meaning
	<b>WARNING</b>	Indicates a potentially hazardous situation which, if not avoided, could result in death or serious injury.
	<b>CAUTION</b>	Indicates a potentially hazardous situation which, if not avoided, may result in minor or moderate injury. It may also be used to show potential damage to property.
	<b>NOTE</b>	Indicates a potentially hazardous situation which, if not avoided, could result in damage of the BISOMAC210.

#### Warning labels attached to Hoists and Devices

The operator must check that the following labels are attached properly and legible.

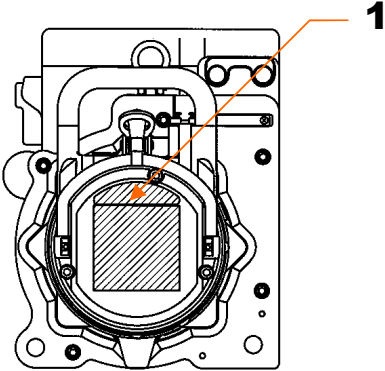
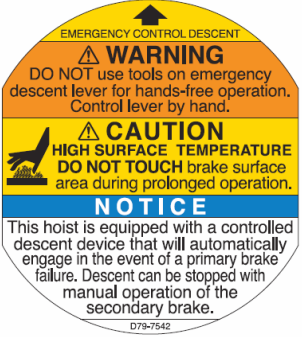
[BISOMAC210 Right Side]		
		
Description	Message / <Location>	Label
1. Emergency Control Descent & Electromagnetic Brake Caution	- Instruction of Emergency Control Descent - Instruction of Electromagnetic Brake <Electromagnetic Brake>	



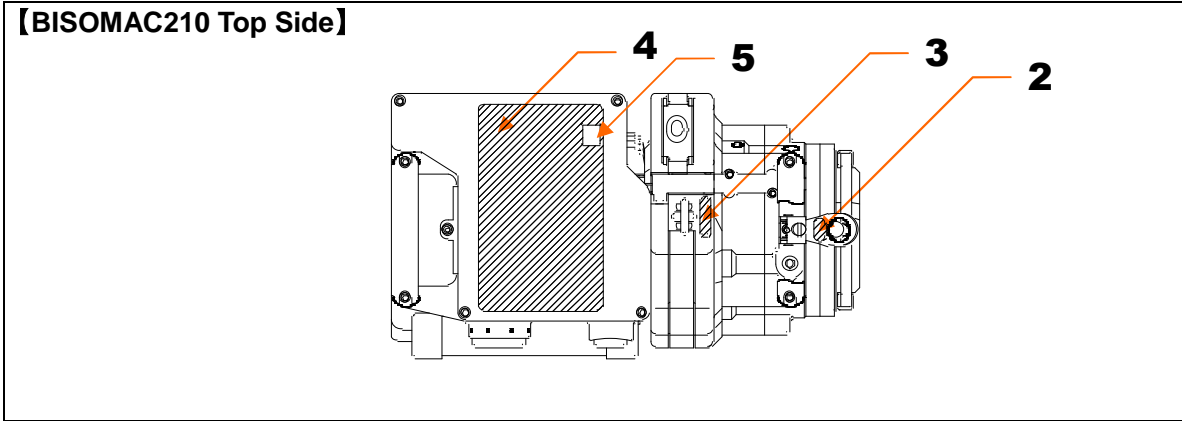



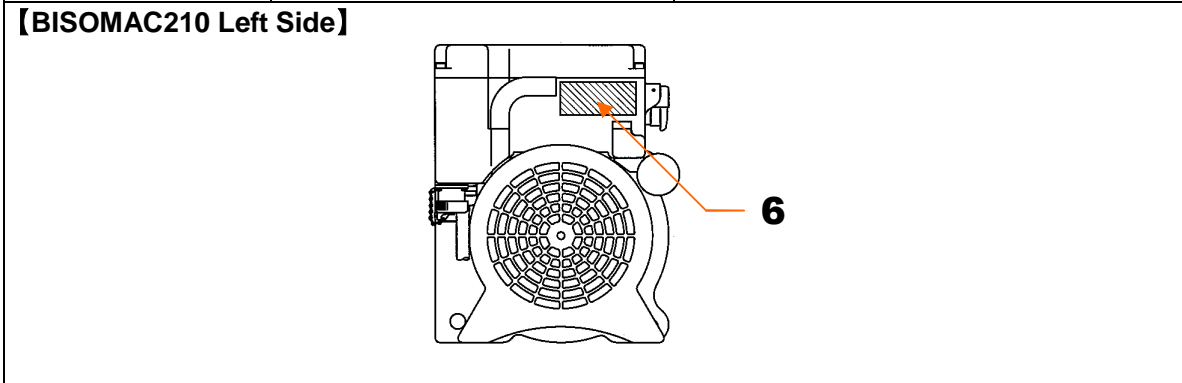

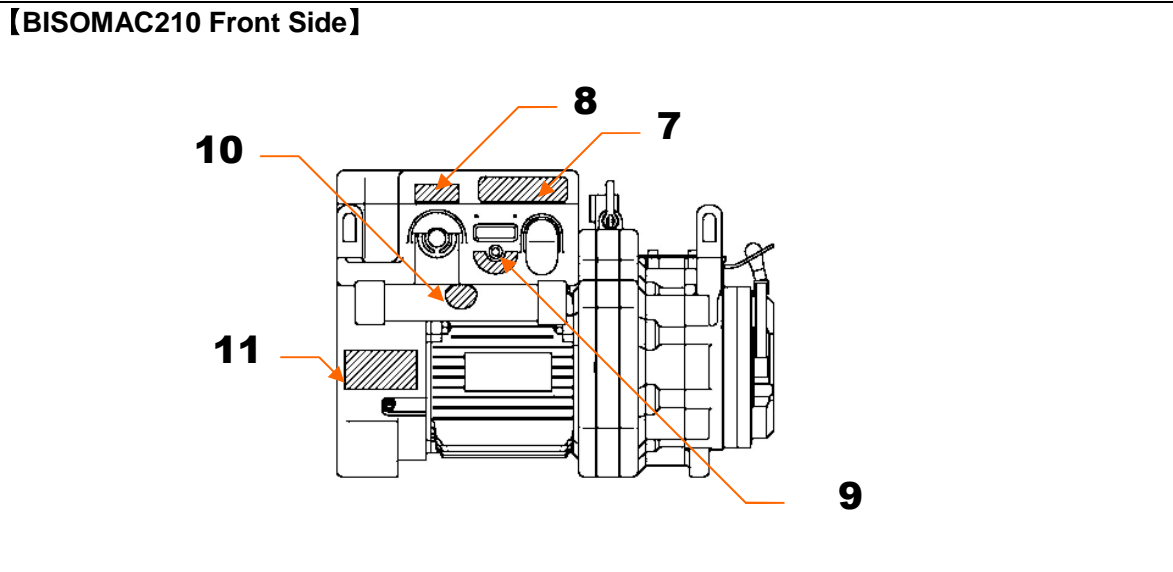

Description	Message / <Location>	Label
2. Lever Stopper	- Instruction of Brake Release Lever Stopper <Lever Stopper>	
3. Max Lift	- Instruction of Shackle max lift. <Casing A>	
4. Speciation and Operation	- Instruction of Specification and operation <Control Box Cover>	
5. QR Code	- Access operator's manual by electronic device <Control Box Cover>	



Description	Message / <Location>	Label
6. Restriction Use	- Instruction to Operator <Control Box>	



Description	Message / <Location>	Label
7. UL Classification	- UL Certification Label <Control Box Cover>	
8. Emergency Stop Button	- Instruction of Emergency Stop Button <Control Box Cover>	
9. Overload Indicator	- Instruction of Overload Indicator <Control Box>	
10. Operator's Manual	- Instruction to Operation Manual <Operator's Manual Holder>	
11. Power Voltage	- Instruction of Power Cable <Power Cable>	

【BISOMAC210 Back Side】		
Description	Message / <Location>	Label
12. Gear 210	- Specification of Gear <Gear Box>	<div style="border: 1px solid black; padding: 5px; width: fit-content;">                     Mechanical Horsepower Rating:1.5kW                      Maximum Input Speed:1950r/min                      Gear Ratio:1/118                      Service Factor:1.0                      Thermal Horsepower Rating:1.5kW                      Use oil as required per the manufacture.                      D79-7772                 </div>
13. Plug Mark	- Instruction of plug mark position of Safety Device <Control Box>	<div style="border: 1px solid black; padding: 5px; text-align: center;"> <p><b>Align the white mark towards the motor</b></p> </div>
14. Plug Connection	- Instruction when connecting the plug of safety device, and pendant switch <Control Box>	<div style="border: 1px solid black; padding: 5px; text-align: center;"> <p><b>⚠ WARNING</b></p> <p>Before connecting, check to make sure the plugs are dry and no water is left inside. Failure to do so may cause malfunction, resulting in serious injury or death.</p> </div>

**[Overspeed Detection Device Right Side]**

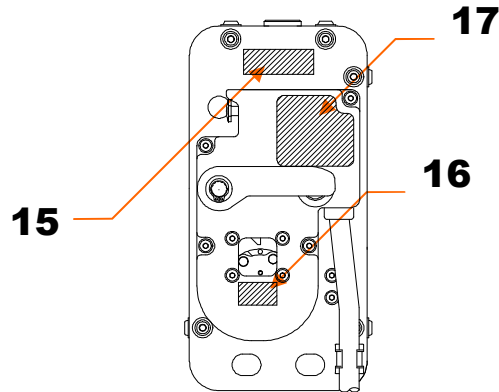



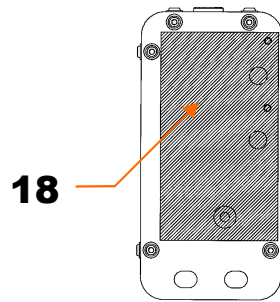

Description	Message / <Location>	Label
15. Instruction of inability of lifting	- Instruction to inability of lifting <Side Plate 1>	
16. Governor Inspection Window	- Instruction of Governor Rotation <Governor Cover>	
17. Overspeed Indicator & Reset	- Instruction of Overspeed Detection Device - Reset Lever Direction <Governor Cover>	

**[Overspeed Detection Device Left Side]**

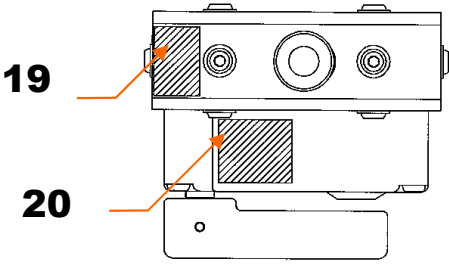

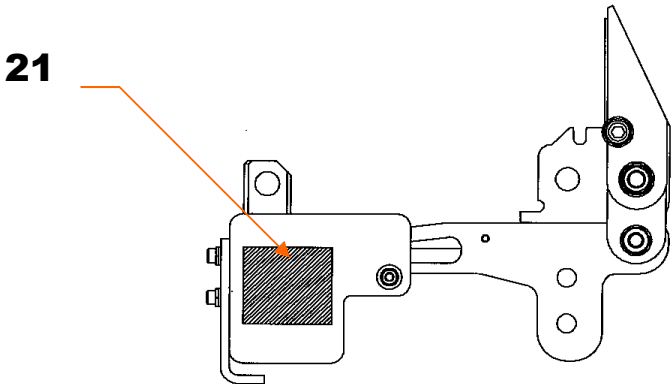
Description	Message / <Location>	Label
18. Instruction of Overspeed Detection Device	- Instruction of Overspeed Detection Device <Side Plate 2>	

【Overspeed Detection Device Top Side】		
		
Description	Message / <Location>	Label
19. Wire Rope Diameter	- Instruction of Wire Rope Diameter <Side Cover 1>	
20. Instruction of Manual Trip Button	- Instruction of Manual Trip Button <Governor Cover>	
【Overload Detection Device Right Side】		
		
Description	Message / <Location>	Label
21. Instruction of Overload Detection Device	- Instruction of Overload Detection Device <Limit Switch Cover LA>	

**【Overload Detection Device Back Side】**

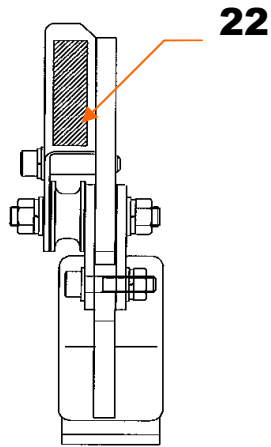

Description	Message / <Location>	Label
22. Wire Rope Exit	- Instruction of Wire Rope Exit <Rope Cover>	

**【Overload Detection Device Front Side】**

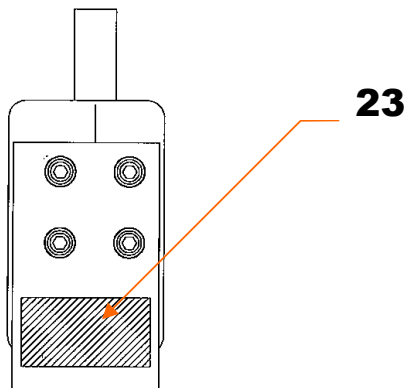

Description	Message / <Location>	Label
23. Rated Load	- Instruction of Rated Load <Guard>	

## 2. SPECIFICATIONS

### 2.1 BISOMAC210 TRACTION HOIST

<b>Model</b>	<b>BISOMAC210-1508U</b>
Rated Load	1500 lbs (680 kg)
Rated Speed	35 ft/min (10.6 m/min)
Noise	64 dB
Protection Construction	IP54
Hoist Self Weight	108 lbs (49 kg)
Weight including safety devices	130 lbs (59 kg) - Overload device:9 lbs (4kg) - Overspeed device: 11 lbs (5kg) – Extension bracket: 2 lbs (1kg)
Dimension w/safety devices	29.5 in. (750 mm high) x 12.4 in. (315 mm width) x 17.9 in. (455 mm depth)
Voltage	1-phase 208 V (60 Hz)
Ampere in Rated load	13 A
Motor Power	1.5 KW (4P)
Wire Rope Dia	dia 5/16 inch or dia 8 mm
Control Method	Independent Control Method
Safety Features	Electromagnetic Brake
	Controlled Descent Device
	Emergency Stop – Cut all power to the electric motor
<b>MAINTENANCE SPECIFICATIONS</b>	
Maintain every 100 hour of operation hour or no longer than every year. See Maintenance Manual for instructions on maintaining. (this differ from condition of use at work sites, refer Section 4 Work Environment)	

<b>OVERSPEED DETECTION DEVICE</b>	
Rated Load:	1500 lbs (680 kg)
Activation Speed:	98.4 ft/min (30 m/min)
Dimension:	10 in. (253 mm high) x 4.7 in. (120 mm width) x 4 in. (103 mm depth)
Weight:	11 lbs (5 kg)
Control Feature:	NO descending while this device is activated.
Use Voltage	208 V

<b>OVERLOAD DETECTION DEVICE</b>	
Rated Load:	1500 lbs (680 kg)
Dimension:	10.4 in. (264 mm high) x 12.4 in. (314 mm width) x 3.7 in. (95 mm depth)
Weight:	9 lbs (4 kg)
Control Feature:	NO ascending while this device is activated.
Use Voltage	208 V

## 2.2 WIRE ROPE



### WARNING

BISOMAC210 operation requires the use of wire rope described below. Using any other wire rope could cause the platform to fall or tilt, possibly resulting in falls and serious injury or death.

	TYPE-1	TYPE-2	TYPE-3	TYPE-4	TYPE-5
Construction	5x26	4x39	4x40	6x19 IWRC	4x26
Diameter	5/16 in. 8.4mm	5/16 in. 8.0mm	5/16 in. 8.0mm	5/16 in. 8.2mm	5/16 in. 8.3mm
Min. Breaking Load (actual)	51.5kN (5253kg)	39.2kN (3998kg)	43.0 kN (4386kg)	40.5 kN (4131kg)	45.0 kN (4590kg)
Treatment	Galvanized	Galvanized	Galvanized	Galvanized	Galvanized
Caution	<b>ONLY USE Wire Rope recommend by Hoist Manufacturer</b>				

## 2.3 Power Cable

Recommended Type	SOOW
Core and Size	3 cores 10 AWG
Rated Voltage	600 V
Max Length	500 ft (152 m) per platform

### NOTE

Due to the various possible suspended platform loading situations and electric voltage sources, it is not possible to specify the maximum power cable length exactly.



**3. FUNCTION AND DESCRIPTION OF EACH COMPONENT**  
**3.1 BISOMAC210 TRACTION HOIST**

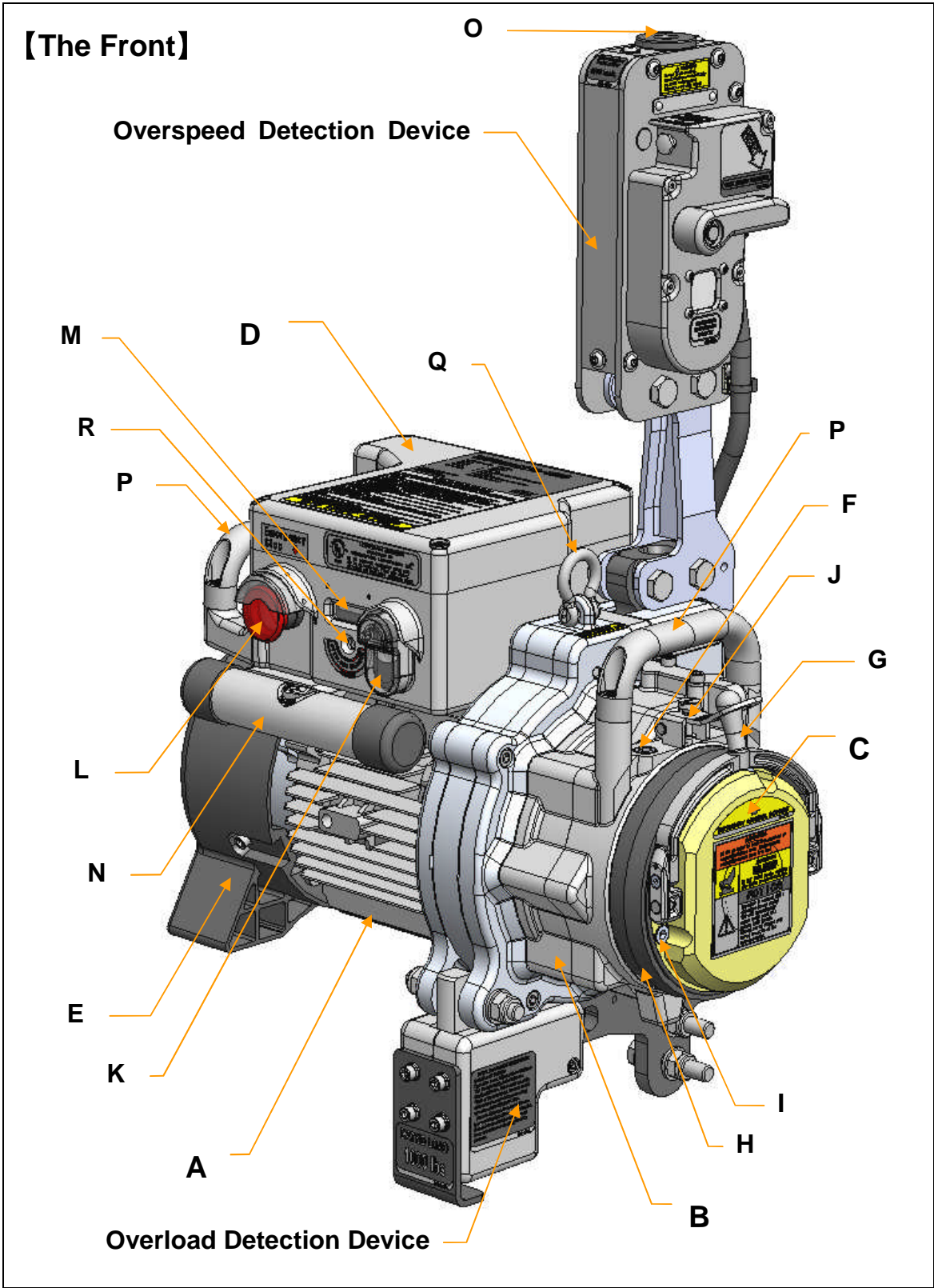

## 【The Back】

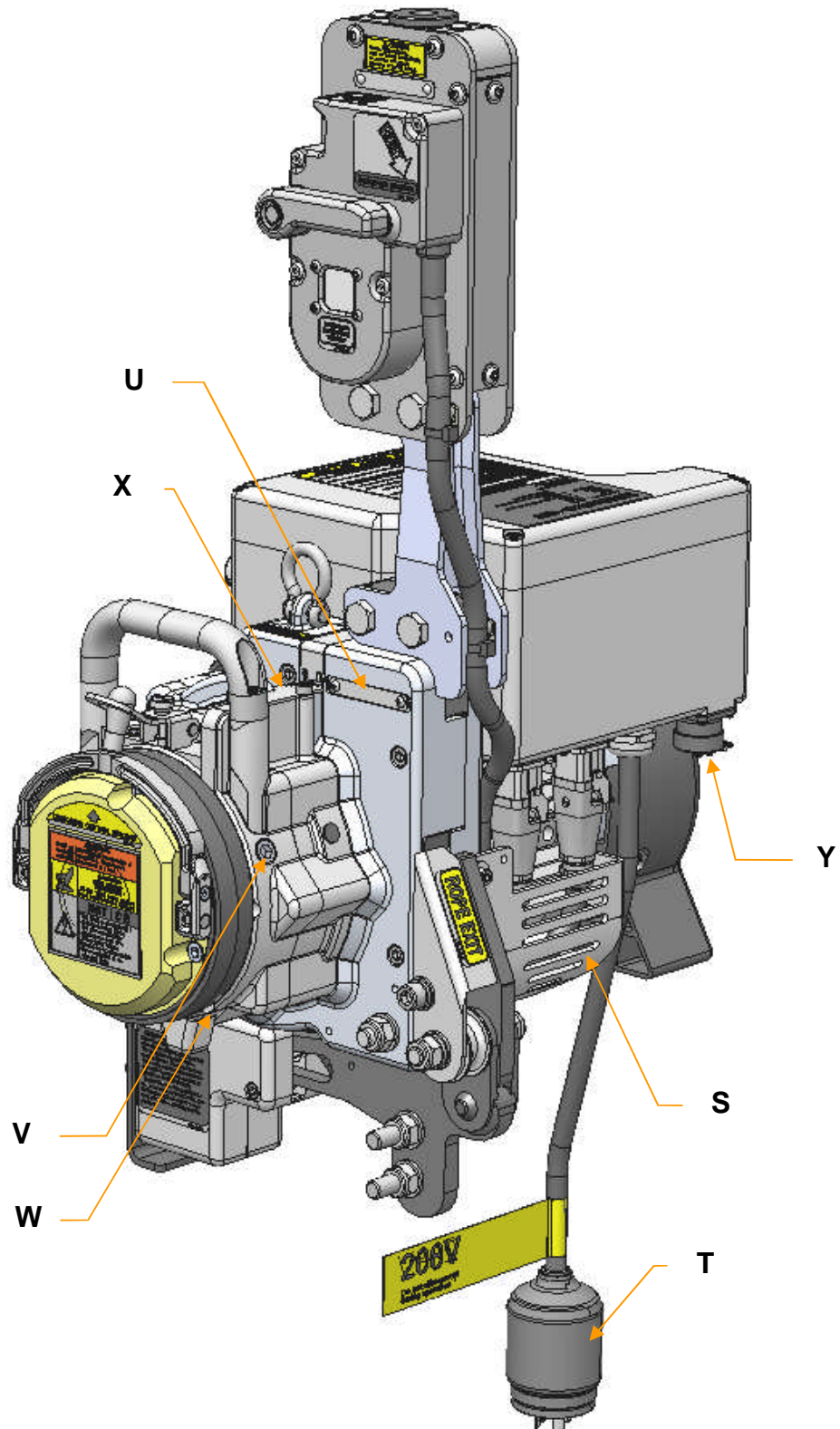

	<b>FUNCTION</b>	<b>DESCRIPTION</b>
A	Electric Motor	BISOMAC210 is powered by electricity through gear drive.
B	Gear Box	Gear Box of BISOMAC210.
C	Electromagnetic Brake	Electromagnetic Brake is released when the Operation Button is pressed. The BISOMAC210 stops when the Operation Button is released or the main power is disconnected.
D	Control Box	Electric components are assembled to control the BISOMAC210 lifting.
E	Fan Cover	Protects operator from being struck by the fan and prevents damage to the fan and motor.
F	Fluid Refill Hole	Use when replacement of oil.
G	Emergency Descent Lever	This allows the platform to be lowered at regular speed when electrical power to the BISOMAC210 is lost.
H	Protection Cover	Does not allow water and dirt to get into Electromagnetic Brake.
I	Water-proof Cap Bolt	Cap bolt with sealing to avoid water getting into the Electromagnetic Brake.
J	Lever Stopper	Prevents misoperation & malfunction of Emergency Descent Lever.
K	Power Indication & Operation Button	The Power Indication is lit when connecting power. Controls the vertical motion of the BISOMAC210. Operation Button disengages when released.
L	Emergency Stop Button with Indicator	This Button is for emergency stop. Press this Button in case the BISOMAC210 does not stop even releasing the Operation Button. The Indication is lit when pressing this Button and cut all power to the electric motor.
M	Hour Meter	Shows the BISOMAC210's integrated operating hours.
N	Operator's Manual Tube	Install Operator's Manual.
O	Suspension Wire Rope Inlet	For inserting main suspension wire rope.
P	Carrying Grips	Carrying Grips for the BISOMAC210.
Q	Shackle for Transportation	Only use at transportation of the BISOMAC210. Max lifting load is 165 lbs (75 kg).
R	Overload Indicator	When Overload Detection Device is activated, this Indicator is lit.
S	Cable Guard	Protection Metal for Cable and Connector.
T	AC Power Plug	This 3-prong power plug and cord are for connecting the BISOMAC210 to the worksite power supply.
U	Serial Number	BISOMAC210 Serial Number.
V	Oil Level Gauge	Use when replacing of oil.
W	Fluid Drain Hole	Use when replacing of oil.
X	Guard Plate for Brake Leads	Protect Brake Leads from damages.
Y	Inlet for Pendant Switch	Allow using Up/Down remote control pendant switch. When not using the pendant switch, keep the receptacle closed by twist-locking the attached waterproof cap. Pendant switch is optional. Please contact local authorized the BISOMAC210 distributor.

### 3.2 Overspeed Detection Device

The Overspeed Detection Device engages wire rope when platform suddenly falls. Once Overspeed Detection Device activates, the platform would not descend due to electric interlock.

**⚠ WARNING**

When platform suddenly falls and the Overspeed Detection Device activates, only trained and authorized personnel are allowed to reset this device. Contact the local authorized BISOMAC210 distributor and wait for rescue of the operators on the platform. Improperly resetting the device may result in the platform falling and tilting, allowing persons or things to fall and possibly resulting in serious injury, death or damage.

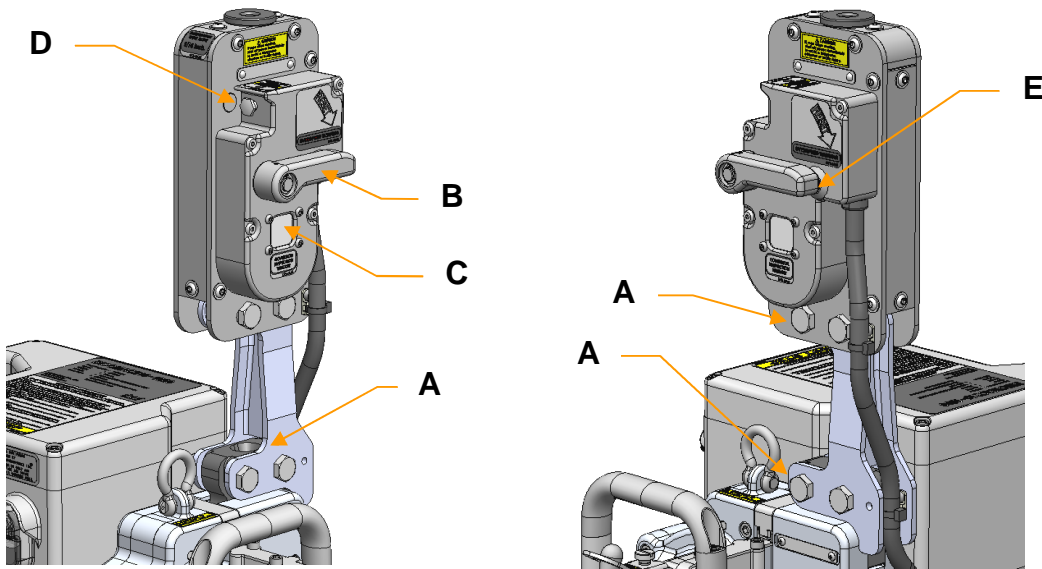

	FUNCTION	DESCRIPTION
A	Extension Bracket for Overspeed Detection Device & Special Bolt	Use to attach Overspeed Detection Device and Extension Bracket to BISOMAC210 (Bolt Q'ty: 4 pieces)
B	Reset Lever	Use for resetting the Overspeed Detection Device. <b>NOTE: When huge power applies to Device such as shock load, attempt to reset forcibly, the Safety Pin in the Lever will damage and will not allow resetting the Lever.</b>
C	Governor Inspection Window	Confirm Rotating of Governor
D	Manual Trip Button	This Trip Button is for manual activation of the Overspeed Detection Device.
E	Overspeed Indicator	In case of activation of the Overspeed Detection Device, the Indicator is lit when pressing "Down" Button.

### 3.3 Overload Detection Device

The Overload Detection Device prevents exceed load from platform. When load on the platform exceeds approximately 1500 lbs (675 kg), the Device detects it and prevents BISOMAC210 from going up. When Overload Detection Device is activated, this Indicator is lit. The Device is also equipped Guide Roller which supports wire rope dereeving from BISOMAC210.

**⚠ WARNING**

Lessen load from platform when platform will not ascend even Up Dutton is depressed or platform will ascend with pumping. The overload may cause the platform to fall or tilt, and consequently operators or objects might fall, resulting in serious injury, death or damage to operators or passers-by.

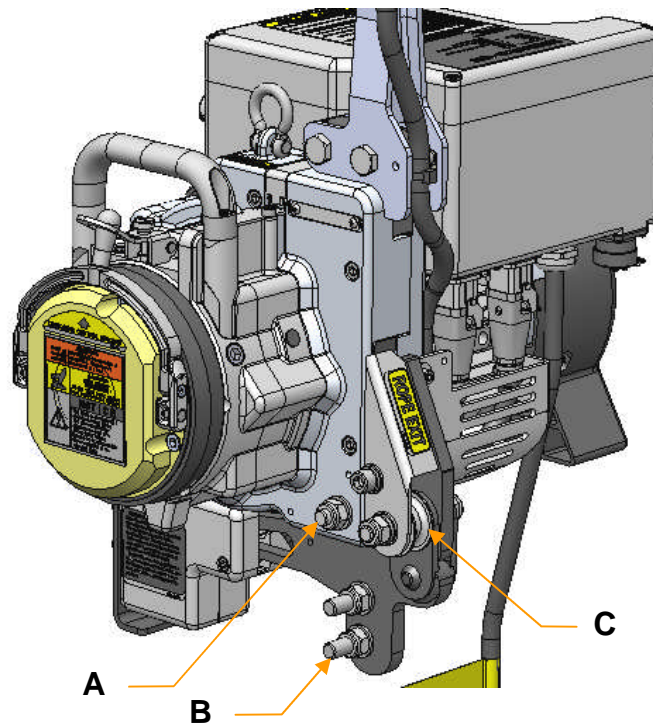

	FUNCTION	DESCRIPTION
<b>A</b>	Special Bolt of Overload Device	Use to attach Overload Detection Device to BISOMAC210 (Q'ty: 2 pcs)
<b>B</b>	Special Bolt of Stirrup	Use to attach Overload Detection Device to Stirrup (Q'ty : 2 pcs)
<b>C</b>	Guide Roller	Guide for supporting end rope load discharging from the hoist.

## 4. WORK ENVIRONMENT

Many work environments contain contaminants that could adversely affect the performance of the BISOMAC210 and the Safety devices. Perform the daily tests described in Section 7 to ensure that the BISOMAC210 is operating properly. If contaminants such as paint, epoxy, cement, corrosive chemicals or sand blasting is present at the work site, use the BISOMAC210 protective cover in accordance with instructions and precautions below on this page.

The protective cover may obstruct some or all of the safety warnings and instruction labels on the BISOMAC210. Before operating the BISOMAC210 equipped with the protective cover, the operator must remove the protective cover and read and understand all of the labels on the BISOMAC210. Each new operator must fully understand all warning and instruction labels before operating the BISOMAC210.

### **WARNING**

ALWAYS test and inspect (Section 7) the BISOMAC210 on a daily basis especially in work environments contains contaminants. Maintain hoist (see Maintenance Manual) after completing work at each work site to remove dusts and foreign objects inside of the hoist. Improper maintenance may result in the platform falling or tilting, allowing persons or things to fall or tilt and possibly resulting in serious injury, death or damage.

### **WARNING**

NEVER use the BISOMAC210 in an explosive atmosphere, under water, or in a marine environment. Especially, use in explosive or wet atmospheres could result in serious injury or death from fire, explosions, or electric shock.

Note: An explosive atmosphere is one in which flammable gases or vapors or small particles are or may be present in the air in quantities sufficient to produce an explosive or ignitable mixture.

### **CAUTION**

Prolonged use of the BISOMAC210 with the protective cover in place may result in the motor overheating due to restricted air supply. This can cause the BISOMAC210 to stop moving. When using the protective cover, be sure that the fan has an unobstructed air supply. Also, stop the BISOMAC210 every 10 minutes to allow the motor to cool.

Note: Wrap the BISOMAC210 in a blanket when it is exposed to freezing temperatures or where water or moisture can enter; to keep the BISOMAC210 from the freezing, otherwise the BISOMAC210 may malfunction.

## 5. SET UP INSTRUCTIONS

This section describes procedure of the BISOMAC210 for safety operation. Before attempting set up, read and understand Steps 1 - 6 of this section which describes the installation procedures of the BISOMAC210 and the safety devices.

### (Warning: Installation)

#### **WARNING**

DO NOT allow anyone under suspended platform. If necessary, provide protection below the suspended platform to prevent potential serious injury or death to passers-by from falling objects.

#### **WARNING**

DO NOT use different types of hoists in the same platform. Otherwise, an operation error may occur from the difference in the hoists' performance (ascending and descending speed, etc.) and the difference of the operation method and the safety unit. This may result in the platform falling or tilting, allowing persons or things to fall or tilt and possibly resulting in serious injury, death or damage.

#### **WARNING**

When attaching the BISOMAC210 to the platform, it is necessary to plan how to attach safety devices in advance, otherwise, the safety devices may not activate. Failure to activate may cause serious injury, death or damage.

#### **WARNING**

Attach earth leakage breaker to power source and ensure that is properly grounded. Failure to do so increases the risk of electric shock or electrocution.

#### **WARNING**

DO NOT use damaged or cracked power cable and control cables. Doing so could result in electrocution or death.

#### **WARNING**

When connecting the plug of safety device to BISOMAC210, verify that inner side of the plug is dry and there is no deposit of water. Due to malfunction of hoist, platform may fall down or topple the operator or the cargo due to tilt, and there is a risk of injury or death of the operator or the passerby.

 **WARNING**

When connecting the plug to the pendant switch inlet, verify that inner side of the plug is dry and there is no deposit of water. Due to malfunction of hoist, platform may fall down or topple the operator or the cargo due to tilt, and there is a risk of injury or death of the operator or the passerby.

 **WARNING**

When you are not using the pendant switch inlet, fully tighten the ancillary waterproof cap and shut the inlet. Due to malfunction of hoist, platform may fall down or topple the operator or the cargo due to tilt, and there is a risk of injury or death of the operator or the passerby.

**(Caution: Connecting Power)**

 **CAUTION**

The Voltage supplied to the BISOMAC210 should not exceed  $10\% \pm$  rated voltage (see rated voltage specification) while lifting. If the voltage is not in the proper range, the BISOMAC210 may not operate or the motor may overheat and malfunction or create a burn hazard.

Note: The rated voltage range shown above should only be permitted to be temporary and not continuous during use of the BISOMAC210.

 **CAUTION**

DO not pull AC power plug or hoist connection cable out by cord. Only pull on the plug or connector.

 **CAUTION**

Use protective cover over the BISOMAC210. Otherwise buttons and indicators may get dirty and malfunction.

 **CAUTION**

Replace rubber cover of the Power Indicator and the Operation Button if they get damage, otherwise, the button and the indicator can get dirty and the control box may malfunction.



**(Warning: Main Wire Rope and Safety Wire Rope)** **WARNING**

The BISOMAC210 operation requires the use of authorized wire rope and the strict adherence to the operation methods and the instructions. If using a wire rope that is not required, the wire rope will have reduced strength and will be served. This may cause the platform to fall or tilt, resulting in falls and serious injury or death.

 **WARNING**

DO NOT expose the wire rope to fire, temperatures above 200° F (93° C), electrical current, or corrosive atmospheres and chemicals. Doing so will reduce the rope's strength and possibly allow the rope to break. This could result in platform falling or tilting, possibly causing serious injury, death or damage.

- Discard the wire rope if any damage is evident after completing the project.
- Discard wire rope that has been exposed to any of these conditions.

 **WARNING**

The suspension wire rope should be long enough (lifting height plus at least 6.56 ft. (2 meter) to cover the height where the platform is placed on the ground or on the specified area. If the wire rope cannot cover the height where the platform can be placed on a stable area, the wire rope may slip out of the BISOMAC210. This may cause the platform to fall or tilt, and consequently operators or objects might fall, resulting in serious injury, death or damage to operators or passers-by.

 **WARNING**

Operating the BISOMAC210 with a wire rope having a kink or deformation may interfere with the up and down movement of the BISOMAC210 and cause damage to the hoist and possibly sever the wire rope. This may cause the platform to fall or tilt, and consequently operators or objects might fall, resulting in serious injury, death or damage to operators or passers-by.

 **WARNING**

When fixing the suspension wire rope and the safety wire rope to the building material, be sure that these wire ropes are not contacting any sharp edge. Otherwise, if the wire rope becomes heavily loaded and severed by a sharp edge, this may cause the platform to fall or tilt, and consequently operators or objects might fall, resulting in serious injury, death or damage to operators or passers-by.

 **WARNING**

The wire rope should be able to go through the inside of the BISOMAC210 freely. Inconsistent winding speed suggests the wire rope or the BISOMAC210 may be damaged. Stop operation at once and replace the wire rope or the BISOMAC210. If the use of damage BISOMAC210 is continued, the wire rope may be severed or the BISOMAC210 may stop. This may cause the platform to fall or tilt, and consequently operators or objects might fall, resulting in serious injury, death or damage to operators or passers-by.

 **WARNING**

DO NOT fasten or apply load to the tail end of the suspension wire rope discharged from the BISOMAC210. Otherwise, the internal parts of the BISOMAC210 will become extremely worn and the wire rope may be damaged or severed. This may cause the platform to fall or tilt, and consequently operators or objects might fall, resulting in serious injury, death or damage to operators or passers-by.

 **WARNING**

DO NOT put your hand near the wire rope inlet when self-reveeing the wire rope and moving the platform up and down. Otherwise, your hand may be caught in the opening along with the wire rope, causing serious injury.

**(Caution: BISOMAC210 Installation)**

 **CAUTION**

DO NOT throw or drop the BISOMAC210. The BISOMAC210 may become damaged and cannot be used and may result in serious injury or property damage.

**STEP1** Installation of Safety Devices to the Hoist

First install the Overspeed Detection Device and Overload Detection Device to Hoist using the instructions below.

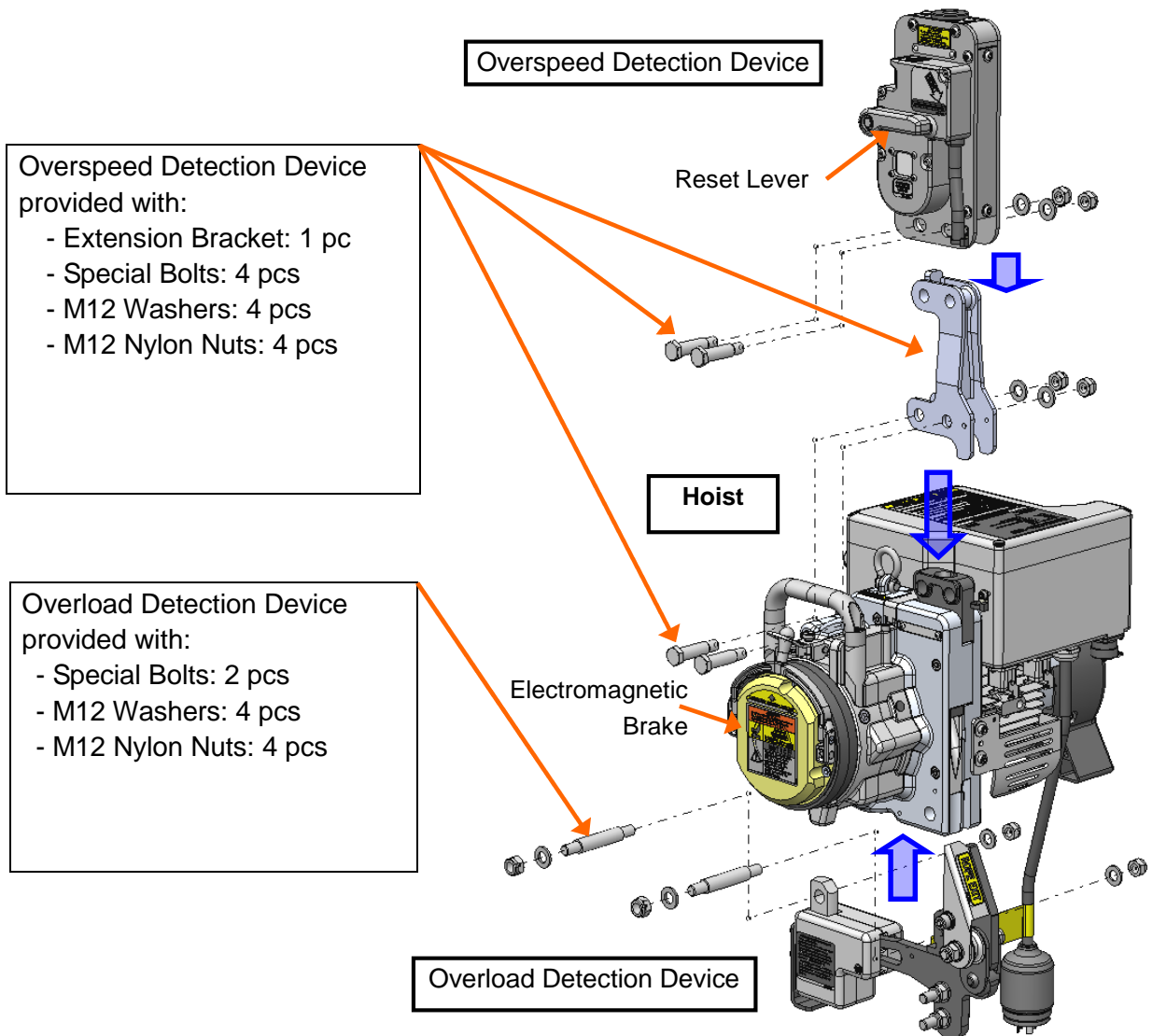

1. Attach the Extension Bracket to the Overspeed Detection Device with tightening 2 Special Bolts, 2 Washers and 2 Nylon Nuts. Insert it into the Hoist from the top as shown and tighten with 2 Special Bolts, 2 Washers, and 2 Nylon Nuts. Install it so that the Electromagnetic Brake and the Reset Lever will be on the same side. Use Torque Wrench to tighten the Bolts.

Torque Standard: 76 N·m (770 kgf·cm)

2. Insert the Overload Detection Device into the Hoist from the bottom as shown and tighten with 2 Fix Bolts, 4 Washers and 4 Nylon Nuts. Use Torque Wrench to tighten the Bolts.

Torque Standard:76 N·m (770 kgf·cm)

3. Connect the Plug of the Overload Detection Device and the Overspeed Detection Device to the Hoist as shown.

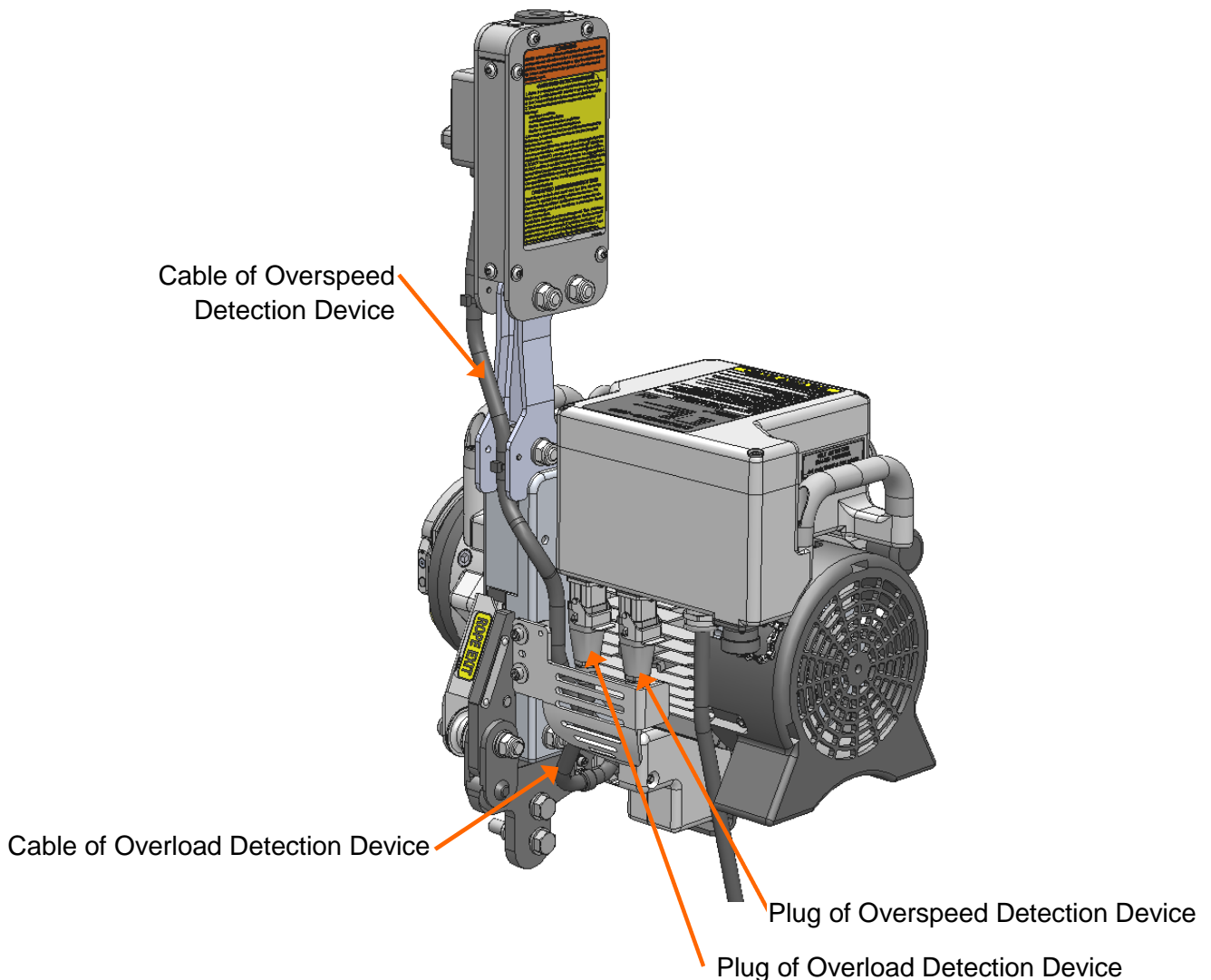

## **STEP 2** Connection of Power Supply

1. Connect the AC Power Plug of the BISOMAC210 to power distribution board.
2. Necessary power is 13 A per the BISOMAC210. If pair of hoists is used on the same platform, install "Y" electric supply yoke in the power line to provide power to each hoist.

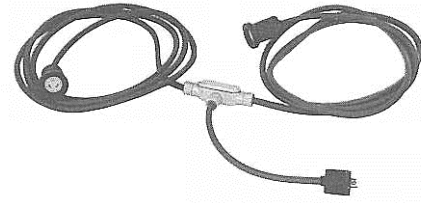

3. Ensure that the Emergency Stop Button of the BISOMAC210 and the interlock of the Safety Devices are set.
4. Ensure that current capacity and size of circuit fuse is adequate. (Refer to specification in section 2)

**STEP 3** Mounting BISOMAC210 to the platform

Press the "UP" Button to lift the BISOMAC210 from ground so that the hole in the Overload Detection Device and the hole in stirrup are lined up, and then attach the hoist to the stirrup as shown in below with 2 Fix Bolts, 4 Washers and 2 Nylon (provided by Nihon Bisoh). Position of the ROPE END should be outside of the platform as shown.

Torque Standard: 76 N·m (770 kgf·cm)

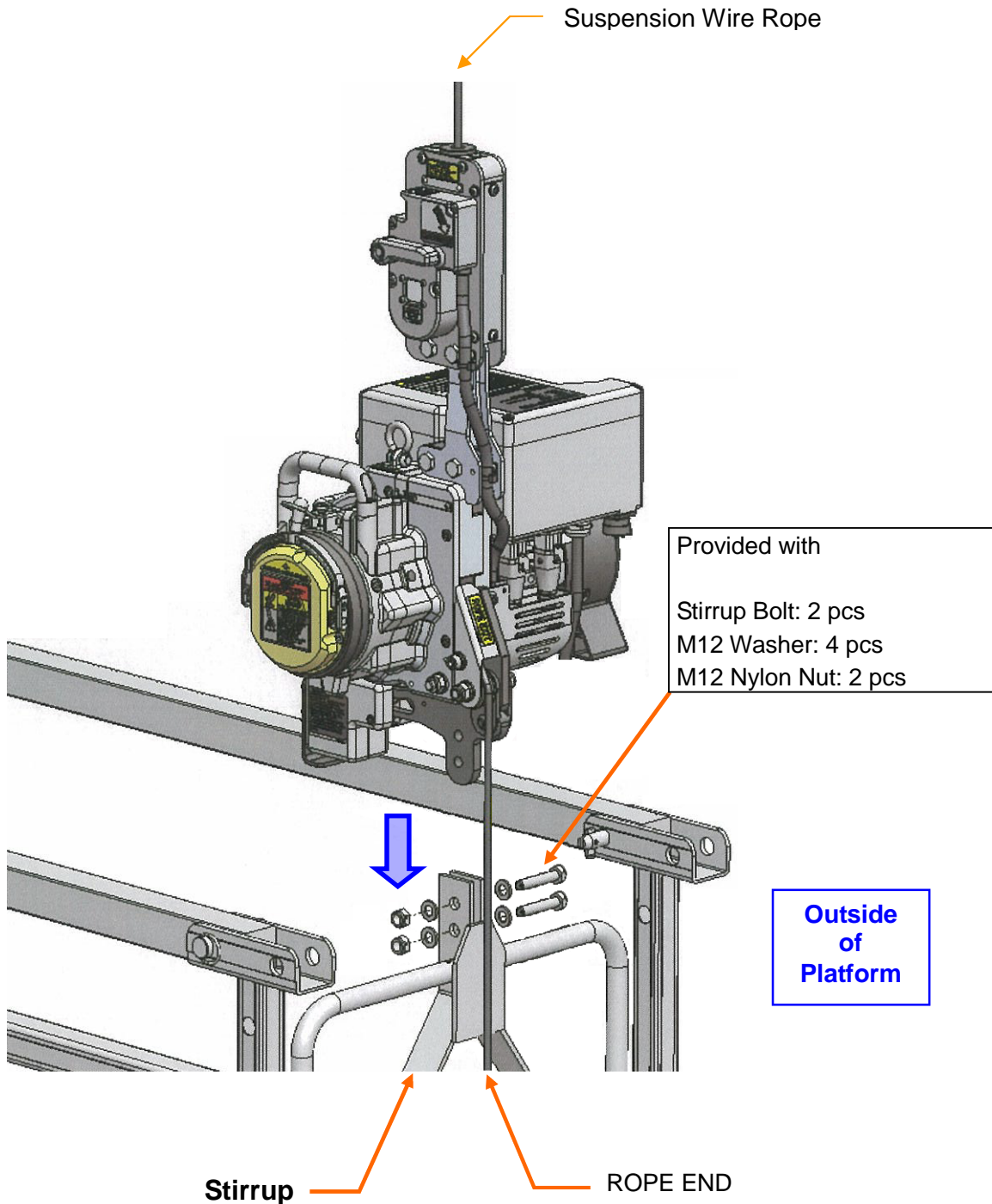

**STEP 4 Main Wire Rope Reeving**

1. Insert the bullet end of the wire rope approximately 16 in. (40 cm) into the suspension wire rope inlet of the BISOMAC210.
2. Press the "UP" Button while maintaining downward pressure on the wire rope until self-reeving starts.
3. Make sure the wire rope can freely exit the BISOMAC210 and is not blocked by any parts.
4. Install the suspension wire rope so that rope-to-rope distance of platform side and rigging side become equal.
5. To avoid run off the suspension wire rope from the BISOMAC210, make the loop on the end of the suspension wire rope and fix it using the clamp as shown in the illustration.

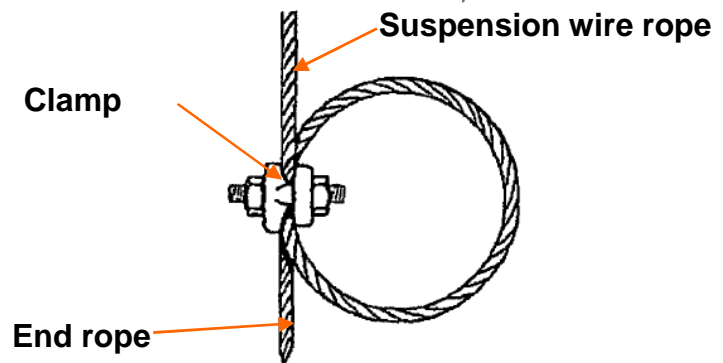
**STEP 5 Confirming Operation of Overspeed Detection Device**

**Perform the following procedure to make sure the Overspeed Detection Device is operating normally.**

1. Insert about 12 in. (30 cm) of wire rope into the Overspeed Detection Device inlet.
2. Pull up the wire rope quickly.  
The Reset Lever turns anticlockwise and the Overspeed Indicator is lit.
3. Make sure that the wire rope is engaged.
4. Make sure the Overspeed Indicator is lit when pressing the "Down" Button.
5. Push down the Reset Lever to reset.
6. Make sure the Overspeed Indicator is not lit when pressing the "Down" Button.

**Perform the following procedures to make sure the Overspeed Detection Device holds loads normally.**

1. Raise the platform about 20 in. (50 cm) off the ground.
2. Press the Manual Trip Button to activate the Overspeed Detection Device.  
The Reset Lever turns anticlockwise and the Overspeed Indicator is visualized.
3. Release the Electromagnetic Brake by pulling the Emergency Descent Lever to lower the platform.

4. The Overspeed Detection Device engages the wire rope and the platform stop descending.
5. Press "Down" Button to confirm the platform will not descent.
6. Confirm that the Overspeed Indicator is lit when pressing "Down" Button.
7. Press down the Reset Lever while pressing "UP" Button to reset the Overspeed Detection Device.
8. Push Operation Button to raise platform and confirm that the Governor is rotating. Perform same procedure to the other side of the Overspeed Detection Device.

If the Overspeed Detection Device does not engage the wire rope, contact the BISOMAC210 local distributor and replace it with a properly functioning Overspeed Detection Device.

#### **STEP 6** Perform Daily Inspection

Follow Daily Tests and Inspections procedures in Section 7.



## 6. OPERATION / HANDLING METHODS

This section describes the following methods to safely handle and operate of the BISOMAC210.

1. Explanation of operation and storage of the BISOMAC210
2. Explanation of operation methods of the BISOMAC210
3. Explanation of each device's function and feature.

### **WARNING**

Each BISOMAC210 operator has to understand the operator's manual and the warning label and manuals before using. If the operator operates the BISOMAC210 improperly, this may cause the platform to fall or tilt, and consequently operators or objects might fall, resulting in serious injury, death or damage to operators or passers-by.

### **WARNING**

DO NOT exceed the maximum load of the BISOMAC210. The rigging portion may fall, resulting in potential of death or injury to operators or passers-by.

#### **(Caution: Storage)**

### **CAUTION**

Remove the Overload Detection Device from the BISOMAC210 (refer to section 5, step 1) before storing hoist. Carefully store the hoist so that it does not fall down and become damaged.

#### **(Warning: Lifting and Emergency Stop)**

### **WARNING**

DO NOT have the Operation Button continuously depressed. Otherwise, the BISOMAC210 cannot stop. This may cause the platform to fall or tilt, and consequently operators or objects might fall, resulting in serious injury, death or damage to operators or passers-by.

### **WARNING**

Always allow the BISOMAC210 to come to a full stop before changing the direction of travel. Failure to do so may result in control circuit failure, or may prevent the BISOMAC210 from stopping. This may cause the platform to fall or tilt, and consequently operators or objects might fall, resulting in serious injury, death or damage to operators or passers-by.

 **WARNING**

DO NOT use the BISOMAC210 if the Emergency Stop Button does not operate. Failure to do so may result in control circuit failure, or may not prevent the BISOMAC210 from stopping. This may cause the platform to fall or tilt, and consequently operators or objects might fall, resulting in serious injury, death or damage to operators or passers-by.

 **CAUTION**

Do not operate the BISOMAC210 more than 30 minutes during any 2 hours period. If you do so, the brake surface will become very hot and could result in burns if it is touched.

**(Warning: Emergency Descent Lever)**

 **WARNING**

Use the Emergency Descent Lever only in the event of loss of electric power. Put the Emergency Descent Lever through the hole of the Lever Stopper and attach it with screw after using. Otherwise, the BISOMAC210 may not stop, and this may cause the platform to fall or tilt, and consequently operators or objects might fall, resulting in serious injury, death or damage to operators or passers-by.

 **WARNING**

DO NOT use the Emergency Descent Lever when operating the Operation Button. Otherwise, the BISOMAC210 may not stop, and this may cause the platform to fall or tilt, and consequently operators or objects might fall, resulting in serious injury, death or damage to operators or passers-by.

 **WARNING**

Confirm that the Emergency Descent Lever is in the vertical position and affixed to the Lever Stopper before moving the BISOMAC210 up and down. If the Emergency Descent Lever is not in the vertical position, the Electromagnetic Brake may malfunction. In such case, even if you try to stop the operation of the Operation Button, the brake may not function properly, causing the platform to continue to descend. This may cause the platform to fall or tilt, and consequently operators or objects might fall, resulting in serious injury, death or damage to operators or passers-by.

 **WARNING**

Always operate the Emergency Descent Lever by hand. Otherwise, the BISOMAC210 cannot be stopped instantly. This may cause the platform to fall or tilt, and consequently operators or objects might fall, resulting in serious injury, death or damage to operators or passers-by.

 **CAUTION**

Be sure to remove the AC Power Plug of the BISOMAC210 from power source before using the Emergency Descent Lever. Otherwise, sudden movement may be induced when the power is regained. This may cause serious injury, death or damage to operators or passers-by.

 **CAUTION**

DO NOT operate the BISOMAC210 by partially releasing the Emergency Descent Lever. Doing so may result in serious burns, overheating of the BISOMAC210 and premature brake wear. If this occurs, the brake may become not repairable.

NOTE: DO NOT use the BISOMAC210 if the platform does not descend using the Emergency Descent Lever. Otherwise, the platform may not descent and it may not be possible to rescue operators in the event of a power failure. DO NOT use the BISOMAC210 until it is repaired and retested.

## 6.1 Carrying BISOMAC210

- Separate the BISOMAC210 and Overload Detection Device and Overspeed Detection Device to safely carry each device (refer to section 5, step 1).
- Carry the BISOMAC210 with 2 persons by grasping the carrying grips.
  - The weigh of the BISOMAC210: approximately 108 lbs (49 kg)
  - The weight of the Safety Devices: approximately 22 lbs (10 kg) (Overload Detection Device, Overspeed Detection Device and Extension Bracket)
- Use the specified bolts and nuts to connect the BISOMAC210 and Overload Detection Device and Overspeed Detection Device (refer to section 5, step 1).

## 6.2 Operation and use of Emergency Stop

- Make sure the BISOMAC210 ascends by pressing “Up” Button and descends by pressing “Down” Button.
- Make sure the BISOMAC210 stops by pressing “Emergency Stop Button” and the BISOMAC210 will not ascend or descend.

### 6.3 Emergency Descent Lever

#### **WARNING**

Do not use tools for hands-free operation of the control descent lever. Always operate the Emergency Descent Lever by hand. Otherwise, the BISOMAC210 cannot be stopped instantly. This may cause the platform to fall or tilt, and consequently operators or objects might fall, resulting in serious injury, death or damage to operators or passers-by.

- In the event of loss of electric power, the BISOMAC210 may be lowered at regular speed using the Emergency Descent Lever.
- If you desire to lower the BISOMAC210:
  - 1) Disconnect the AC Power Plug of the BISOMAC210 from Power source.
  - 2) Loosen the Screw and lift the Lever Stopper for the Electromagnetic Brake up.
  - 3) Release the Electromagnetic Brake by gently pulling the Emergency Descent Lever as far as it will go toward the arrow as shown. The BISOMAC210 safely lowers at regular speed.
  - 4) Release hand from the Emergency Descent Lever to stop the BISOMAC210.

NOTE: DO not apply exceed load on Emergency Descent Lever. The pin will break if approximately 220 lbs power is applied and will not able to descent in emergency condition. Refer to Maintenance manual to repair the pin.

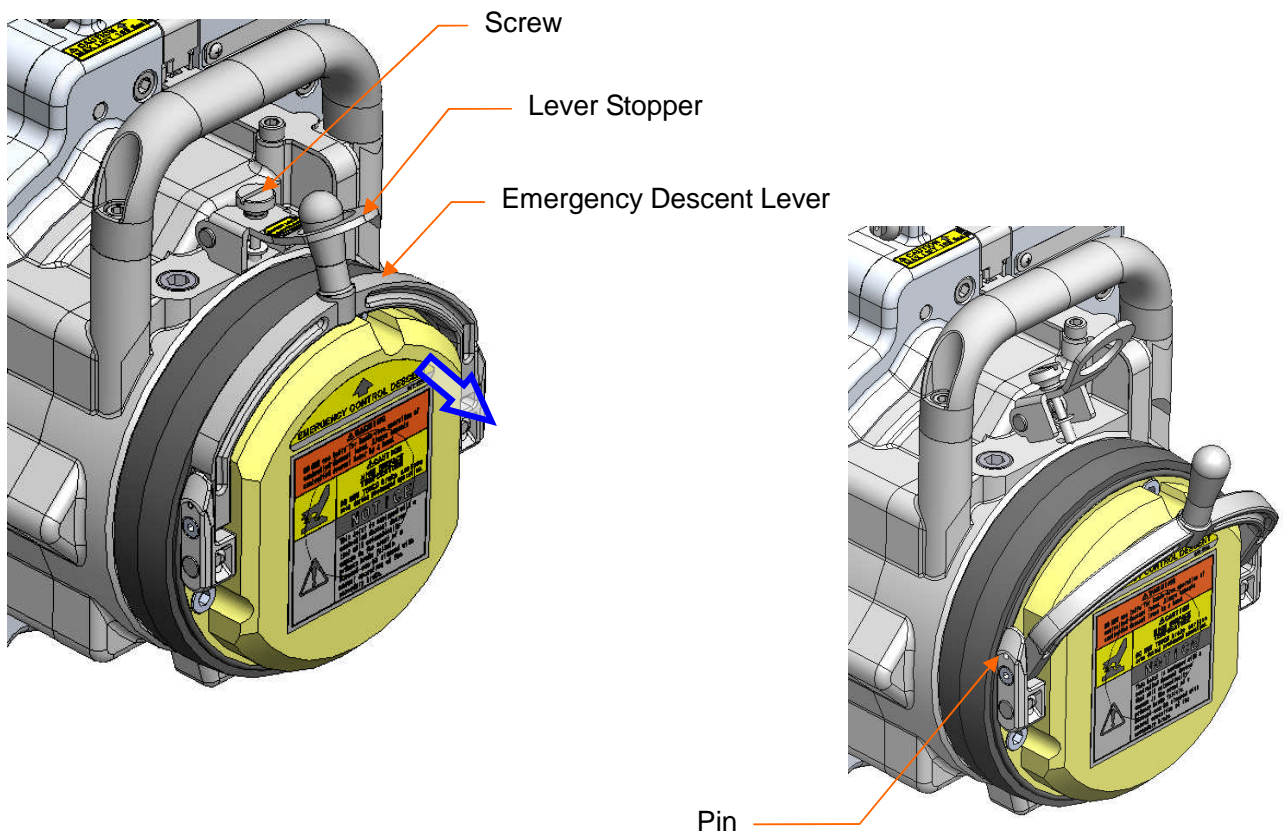

## 7. DAILY TESTS AND INSPECTIONS

This section describes necessary test procedure before and after installation of the BISOMAC210.

- Read and understand Steps 7.1-7.5 of this section describing the inspection and installation procedures of the BISOMAC210 before attempting use.
- Follow each devices maintenance manuals if the daily tests and inspections are not described in this manual.

### **WARNING**

DO NOT allow anyone under suspended platform. If necessary, provide protection below the suspended platform to prevent potential of death or injury to passers-by from falling objects.

### **WARNING**

NEVER perform any disassembly, maintenance, repair, or part replacement on the BISOMAC210 when it is suspended in air or is under load. This may cause the platform to fall or tilt, and consequently operators or objects might fall, resulting in serious injury, death or damage to operators or passers-by.

### **WARNING**

ALWAYS test and inspect the BISOMAC210 on a daily basis, otherwise the BISOMAC210 may malfunction. This may cause the platform to fall or tilt, and consequently operators or objects might fall, resulting in serious injury, death or damage to operators or passers-by.

#### **(Warning: Test Procedure of Rigging Metal)**

### **WARNING**

If the Rigging is in an abnormal condition, STOP to use platform. If the wire rope runs out from rigging or wire rope is cut, this may cause the platform to fall or tilt, and consequently operators or objects might fall, resulting in serious injury, death or damage to operators or passers-by.

#### **(Warning: Test Procedure of Wire Rope)**

### **WARNING**

The wire rope will wear out with repeated operation. Therefore, it must be regularly inspected to be sure it is in good condition. If you use a wire rope that is deformed or damaged, it will have reduced strength and may break. This may cause the platform to fall or tilt, and consequently operators or objects might fall, resulting in serious injury, death or damage to operators or passers-by.

**(Warning: Test Procedure of Lifting Platform and Emergency Stop Function)**

 **WARNING**

If you hear any strange noises such as grinding during operation or if the BISOMAC210 does not appear to work normally, STOP it immediately. DO NOT continue to use the BISOMAC210 until it is replaced. It is possible that parts inside the BISOMAC210 have been damaged. Continuing to use the BISOMAC210 may cause the platform to fall or tilt, and consequently operators or objects might fall, resulting in serious injury, death or damage to operators or passers-by.

 **WARNING**

If the BISOMAC210 is suspended in the air and the motor is running but the wire rope is not moving through the BISOMAC210, STOP the BISOMAC210 immediately. Damaged wire rope may be jammed inside the BISOMAC210. Any attempt to move the BISOMAC210 up or down can damage the equipment and/or sever the wire rope, making the BISOMAC210 unable to sustain a load. This may cause the platform to fall or tilt, and consequently operators or objects might fall, resulting in serious injury, death or damage to operators or passers-by.

 **WARNING**

DO NOT use the BISOMAC210 if the Indication light does not go on when the Emergency Stop Button is pressed. Otherwise, the Emergency Stop device may not be operating and this may cause the platform to fall or tilt, and consequently operators or objects might fall, resulting in serious injury, death or damage to operators or passers-by.

**(Warning: Test Procedure of Controlled Descent Device)**

 **WARNING**

If the BISOMAC210 has a defect, replace it with one that has passed the pre-shipment inspection by certified personnel. A BISOMAC210, which has not passed the pre-shipment inspection, may malfunction or not perform normally. This may cause the platform to fall or tilt, and consequently operators or objects might fall, resulting in serious injury, death or damage to operators or passers-by.

**(Warning: Test Procedure of Overspeed Detection Device)**

 **WARNING**

DO NOT use the BISOMAC210 if the Overspeed Detection Device does not engage the wire rope. Replace it with a properly operating Overspeed Detection Device, failure to do so may cause the suspension wire rope to be cut, the platform to fall or tilt, and consequently operators or objects might fall, resulting in serious injury, death or damage to operators or passers-by.

## 7.1 Test Procedure for Rigging

Inspect all components of the suspended platform, especially the components supporting loads, to be sure there are no signs of damage or excessive wear and that all fasteners (nuts, bolts, clamps, wire-clip, shackle, etc.) are properly and securely tightened.

## 7.2 Test Procedure for Wire Rope

### 7.2.1 Wire Rope and profile and dimension

- Wire rope **MUST** be taken out of service when **ANY** of the following conditions apply: (refer Photo)

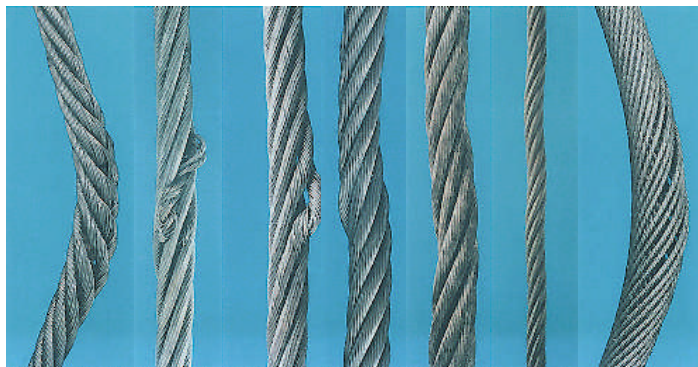

- 1) Loose, kinked, crushed, bird caged wire rope, waviness (more than  $4/3d$ ) or any damage resulting in distortion of the rope structure.
- 2) More than 10% broken wires in one lay.

Example: Wire Rope construction 6 x 19

$$6 \times 19 = 114 \text{ wires} \times 10 \% = 11 \text{ wires}$$



- 3) Reduction of wire rope diameter's average: under dia. 0.308 in. (7.8 mm).
- 4) Increase of wire rope diameter's average: exceed dia. 0.330 in. (8.4 mm).
- 5) Pitting on wire surfaces due to rusting corrosion.
- 6) Evidence of exposure to temperatures above 200° F (93° C).

- Measure the diameter across the widest part of the strands, not the valleys, when the rope is under load.

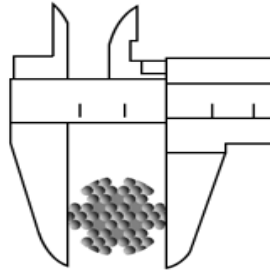

NOTE: DO NOT use wire rope that has been worn, kinked, bird caged or damaged. Replace it with new wire rope

### 7.2.2 Preparation of the end of the wire rope

- The end of the wire rope must be prepared for insertion into the BISOMAC210.

NOTE:

Improperly prepared bullet can cause the wire rope to jam in the BISOMAC210 and the wire does may get stuck in the hoist.

- The end of the wire rope treatment is as shown in the photo.

**Wire rope diameter: 0.315 in (8 mm) – 0.33 in (8.4 mm)**

Braze distance: within 0.197 in (5 mm)

Top Radius: R 0.12 in (3 mm)

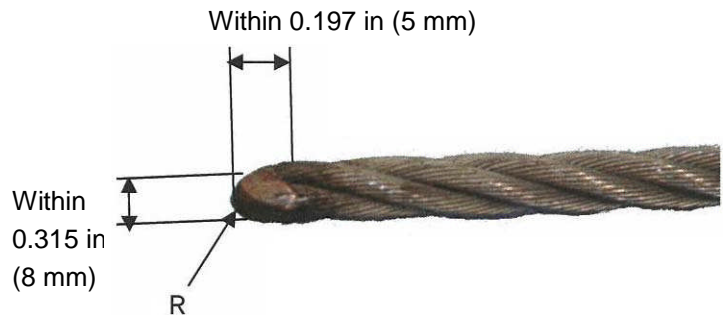



### 7.3 Test procedures for Lifting and use of the Emergency Stop

- 1) Make sure the BISOMAC210 is connected to the stirrup properly and the AC Power Plug is connected to connection plug properly.
- 2) Raise the platform about 40 in. (100 cm) off the ground and then lower it to its original position. Repeat this procedure several times.
- 3) Press the Emergency Stop Button to disconnect the power to the BISOMAC210.
- 4) Make sure that the Indication light for the Emergency Stop Button is lit.
- 5) Press the Operation Button to confirm that the BISOMAC210 will not operate.
- 6) Reset the Emergency Stop Button and confirm that the BISOMAC210 will operate.

#### Testing procedure when remote control pendant switch is connected

- 1) Verify whether the mounting state of BISOMAC210 and platform is appropriate and whether the power supply cable is connected to BISOMAC210 (power supply state).
- 2) Press the Operation Button of the Pendant Switch to lift the platform about 40 in. (about 100 cm) from the ground surface, and lower it to the original position once again. Repeat this couple of times.
- 3) Press the Emergency Stop Button of the main body and shutdown the power supply of BISOMAC210.
- 4) Verify that the red color display lamp of the Emergency Stop Button of the main body lights up.
- 5) Press the Operation Button of the Pendant Switch and verify that BISOMAC210 doesn't operate.
- 6) Press the Operation Button of the main body and verify that BISOMAC210 doesn't operate.
- 7) Reset the Emergency Stop Button of the main body, and verify that the platform moves up and down once again.

#### Perform following test procedure, when Remote Control Pendant Switch has Emergency Stop Bottom.

- 1) Press the Emergency Stop Button of the Pendant Switch and shutdown the power supply of BISOMAC210.
- 2) Verify that the red color display lamp of the Emergency Stop Button of the main body lights up.
- 3) Press the Operation Button of the Pendant Switch and verify that BISOMAC210 doesn't operate.
- 4) Press the Operation Button of the main body and verify that BISOMAC210 doesn't operate.
- 5) Reset the Emergency Stop Button of the Pendant Switch, and verify that the platform moves up and down once again.

## 7.4 Test procedures for Controlled Descent Device

- 1) Raise the platform about 40 in. (100 cm) off the ground.
- 2) Disconnect power at the AC Power Plug of the BISOMAC210 from power source..
- 3) Loosen the Screw and lift up the Lever Stopper for the Electromagnetic Brake.
- 4) Release the Electromagnetic Brake by gently pulling the Emergency Descent Lever as far as it will go toward the arrow shown below. The BISOMAC210 should safely lower at regular speed.
- 5) The platform should descend at a controlled speed not greater than 35 ft/min (10.6 m/min).

If the descent speed exceeds 35 ft/min (10.6 m/min) contact local BISOMAC210 distributor.

## 7.5 Test procedures for Overspeed Detection Device

**Perform the following procedure to confirm of the Overspeed Detection Device is operating normally.**

- 1) Insert about 12 in. (30 cm) of wire rope into the Overspeed Detection Device inlet.
- 2) Pull up the wire rope quickly.  
The Reset Lever turns anticlockwise and the Overspeed Indicator is lit.
- 3) Make sure that the wire rope is engaged.
- 4) Make sure the Overspeed Indicator is lit when pressing the "Down" Button.
- 5) Push down the Reset Lever to reset.
- 6) Make sure the Overspeed Indicator is not lit when pressing the "Down" Button.

**Perform the following procedures to make sure the Overspeed Detection Device holds loads normally.**

- 1) Raise the platform about 20 in. (50 cm) off the ground.
- 2) Press the Manual Trip Button to activate the Overspeed Detection Device.  
The Reset Lever turns anticlockwise and the Overspeed Indicator is visualized.
- 3) Release the Electromagnetic Brake by pulling the Emergency Descent Lever to lower the platform.
- 4) The Overspeed Detection Device engages the wire rope and the platform stop descending.
- 5) Press "Down" Button to confirm the platform will not descent.
- 6) Confirm that the Overspeed Indicator is lit when pressing "Down" Button.
- 7) Press down the Reset Lever while pressing "UP" Button to reset the Overspeed Detection Device.
- 8) Push Operation Button to raise platform and confirm that the Governor is rotating.  
Perform same procedure to the other side of the Overspeed Detection Device.

If the Overspeed Detection Device does not engage the wire rope, contact the BISOMAC210 local distributor and replace it with a properly functioning Overspeed Detection Device.

## 8. PERIODIC INSPECTIONS

The BISOMAC210 has to conduct the following periodic inspections if the BISOMAC210 experiences the following conditions. The periodic inspections have to be performed by certified personnel.

The following time periods should be used to determine to perform periodic inspections. However, depending on job and environmental conditions, periodic inspections may need to be done sooner.

- 1) Unit is more than 1 year old after purchasing
- 2) Unit over 1 year after previous periodic inspection
- 3) Unit operation hour is over 100 hours since last periodic inspection
- 4) When BISOMAC210 used in a bad work environment, such as dirt, dust, etc.

Follow maintenance manual (see Hoist Maintenance Manual) concerning periodic inspections.

### **WARNING**

ALWAYS test and inspect the BISOMAC210 on a daily basis, otherwise the BISOMAC210 may malfunction. This may cause the platform to fall or tilt, and consequently operators or objects might fall, resulting in serious injury, death or damage to operators or passers-by.

### **WARNING**

ALWAYS test and inspect the BISOMAC210 on a daily basis especially in work environments that contain contaminants. Maintain hoist (see maintenance manual) after completing work at each work site to remove dusts and foreign objects inside of hoist. Failure to do so may cause the platform to fall or tilt, and consequently operators or objects might fall, resulting in serious injury, death or damage to operators or passers-by.

### **WARNING**

Only trained and certified personnel may replace the brake, motor, or gearbox. Otherwise, the BISOMAC210 may malfunction or not perform normally. This may cause the platform to fall or tilt, and consequently operators or objects might fall, resulting in serious injury, death or damage to operators or passers-by.

### **WARNING**

DO NOT replace any BISOMAC210 parts with ones that are not approved. Such replacement may cause the BISOMAC210 to malfunction or not perform adequately. This may cause the platform to fall or tilt, and consequently operators or objects might fall, resulting in serious injury, death or damage to operators or passers-by.

## 9. TROUBLESHOOTING AT JOB SITE

### (Problem from Mishandling)

The following information is intended to help identify faults that can occur and recommended correction(s).

 **WARNING**

If the problems (case 1 – case 8) cannot be solved by performing the corrective measures below, replace the hoist or contact local authorized BISOMAC210 distributor. All repairs and solution of these problems must be performed by trained and certified service personnel, otherwise, this may cause the platform to fall or tilt, and consequently operators or objects might fall, resulting in serious injury, death or damage to operators or passers-by.

Problem	Probable Causes	Solution
<b>CASE (1)</b>  <i>Press “UP” or “Down” Buttons but BISOMAC210 will not Operate.</i>	Main power is not connected.	Confirm the main power and the AC Power Plug connections are proper.
	Emergency Stop Button is pushed.	Check the Power Indication and reset the Emergency Stop Button.
	Overload protection feature is activated due to overload.	Unload the weight in platform.
Problem	Probable Causes	Solution
<b>CASE (2)</b>  <i>Press “UP” Button, but BISOMAC210 will not Ascent.</i>	Overload Detection Device’s connection is disconnected.	Check the Overload Detection Device’s connection
	Weight is exceeded.	Check the Overload Indicator is lit and Unload the weight in platform
	Voltage is too low.	Supply power within allowable power of BISOMAC (see 2.1)
	Power Cable is too long or size is too small.	Shorten power cable or use larger size.
Problem	Probable Causes	Solution
<b>CASE (3)</b>  <i>Motor runs but Hoist will not self-reeve</i>	Inadequate bullet on the wire rope.	Make sure the proper wire rope is used. (see 7.2.2)
	Wire rope is worn or damaged.	Stop operation of the BISOMAC210 immediately and replace wire rope.

	The exit of wire rope is blocked.	Remove obstruction which caused blockage.
<b>Problem</b>	<b>Probable Causes</b>	<b>Solution</b>
<b>CASE (4)</b>  <i>Hoist self-reeves, but will not lift platform</i>	Inadequate bullet on the wire rope.	Make sure the proper wire rope is used. (see 2.2)
	Wire rope is worn or damaged.	Replace wire rope.
<b>Problem</b>	<b>Probable Causes</b>	<b>Solution</b>
<b>CASE (5)</b>  <i>BISOMAC210 ascending speed is too low.</i>	Power voltage is too low	Check that voltage and power cable are correct (see 2.1) Supply proper voltage.
	Wire rope is worn or damaged.	Replace wire rope.
<b>Problem</b>	<b>Probable Causes</b>	<b>Solution</b>
<b>CASE (6)</b>  <i>BISOMAC210 makes unusual noise</i>	Each device's bolts and nuts are loosened.	Check them and tighten properly.
<b>Problem</b>	<b>Probable Causes</b>	<b>Solution</b>
<b>CASE (7)</b>  <i>BISOMAC210 is too hot</i>	Voltage of input power is too high	The supply voltage should not exceed +10 % (see 2.1)
	Air supply to Motor is in bad condition	Improve air ventilation on protection cover of BISOMAC210
	Frequency use of BISOMAC210	Strict observance of BISOMAC210 operation hours (see 6)
<b>Problem</b>	<b>Probable Causes</b>	<b>Solution</b>
<b>CASE (8)</b>  <i>BISOMAC210 will not descend.</i>	Connector of Overspeed Detection Device is unplugged.	Connect Connector of Overspeed Detection Device properly.
	Overspeed Detection Device may be activated.	Reset Overspeed Detection Device.



## 2) Inside of Control Box Cover and Control Box

### 【Control Box Cover】

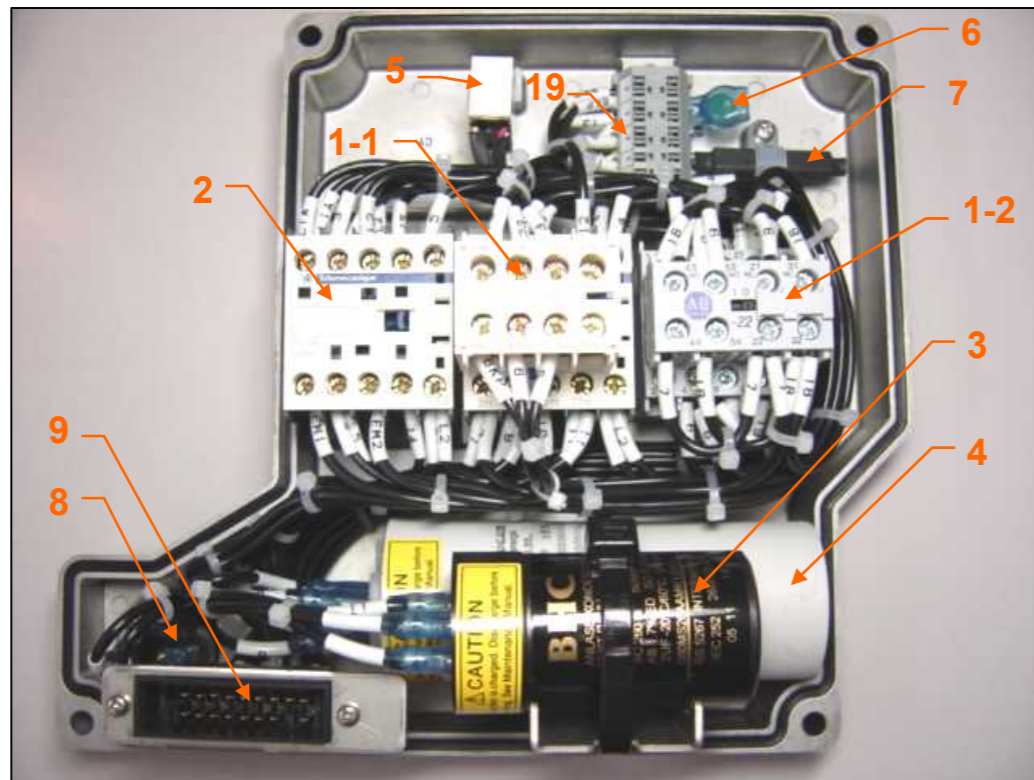

Photo-1

### 【Control Box】

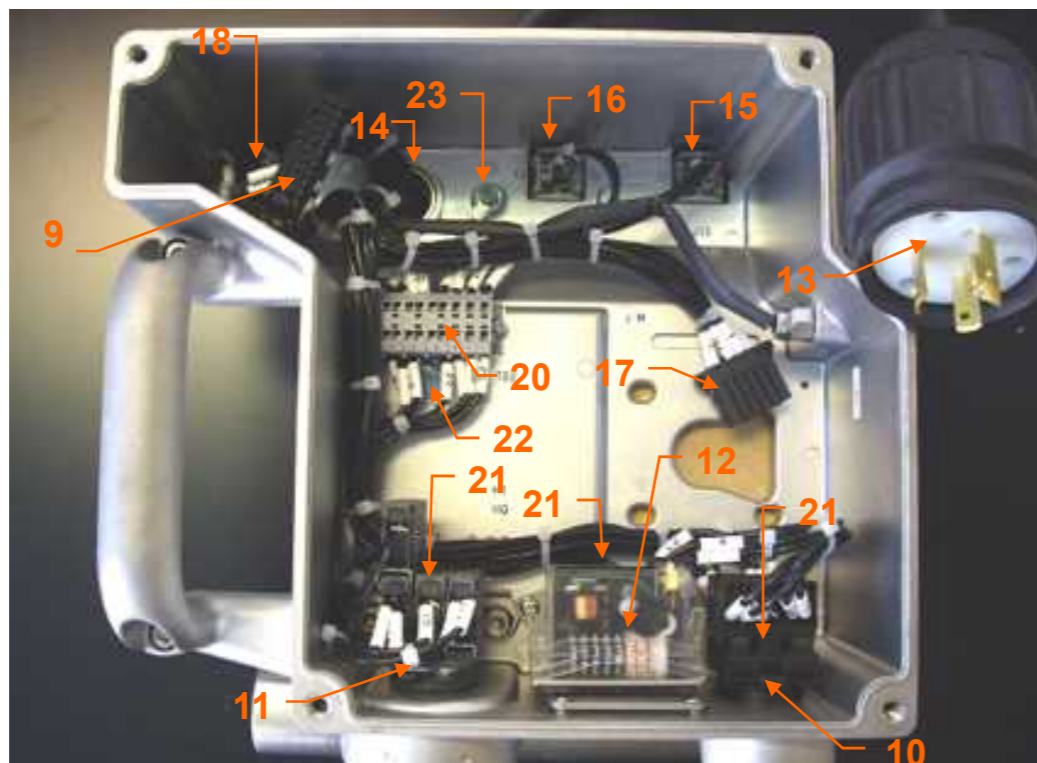

Photo-2

## 3) Part Name and Part Function

### 【Control Box Cover】

No.	Tag No.	Part Name	No.
1-1	MC-1	Electromagnetic contactor for starting motor	Starts Motor
1-2	MC-2	Electromagnetic contactor for running motor	Controls rotation of Motor.
2	ER	Electromagnetic contactor for emergency stop	Turns off the main power.
3	Cs	Starting condenser	Supplies the starting torque to the motor.
4	Cr	Running condenser	Supplies the running torque to the motor and controls the descending speed at the time of manual brake release.
5	AD	Brake power	Supplies the power to the electromagnetic brake.
6	VA	Varistor	Prevents the contact from being damaged by surge voltage.
7	R	Discharge resistance	Prevents the contact from being damaged by surge current.
8	TH-2	Thermal protector	Detects overcurrent and turns off the power.
9	P-B/J-B	Control box connector	Connects the Control box and the Control box cover.
19	TB1	Terminal	Connects and branch wires

### 【Control Box】

No.	Tag No.	Part Name	No.
10	PB	Ascending/Descending button	Controls the electromagnetic contactor and electromagnetic brake.
11	ES	Emergency stop switch	Turns off the power to the control circuit.
12	HQ	Operating time integrating meter	Displays the operating time.
13	PO	Power plug	Connect the power cable.
14	CNO	Power cable ground	Secures the power cable.
15	J13	Socket for the overload detection type rope engaging device	Connect the interlock of the overload detection device.
16	J14	Socket for the overspeed detection type rope engaging device	Connect the interlock of the overspeed detection device.
17	J-M/P-M	Motor connector	Connects the motor and the control box.
18	J-PS	Socket for the pendant switch (option)	Connect the optional pendant switch.
20	TB2	Terminal	Connects and branch wires
21	PE·ES·H1	PB: Power supply injection lamp ES: Emergency Stop Activation Lamp H1: Overload Activation Lamp	Inform the working conditions of the device to operator by lighting and lights out of the lamp
22	R2	Resister	Light out of the lamp by induced current
23	E	Ground	Prevent damage and electric shock of the device by the short circuit and over voltage





## Revision History

Date	Version	Revised Section	Revision
July. 2010	First revision	Drawing	Electric Circuit revised / Brake Label revised
Nov. 2011	Second revision	Drawing	Electric Circuit revised
Mar. 2013	Third revision	Labels	Add QR code and Gear Label
Dec. 2013	Fourth revision	0.2)	Humidity deleted.
June. 2014	Fifth revision	1.3	Power Voltage Label revised
June. 2014	Fifth revision	1.3	Add Plug mark and Plug Connection Label
June. 2014	Fifth revision	5	Add 3 items on Warning Installation
June. 2014	Fifth revision	7.3	Add "Testing procedure when remote control pendant switch is connected"
January 216	Sixth revision	1.3	Categories of Safety Instructions

**BISOMAC210**  
**Electric Traction Hoist**  
**Operator's Manual**  
**Model: BISOMAC210-1508U**

The first edition: March 11, 2009  
The first revision: July 2010  
The second revision: November 2011  
The third revision: March 2013  
The fourth revision: December 2013  
The fifth revision: June 2014  
The sixth revision: January 2016



Published by:  
Overseas Department  
Nihon Bisoh Co., Ltd.  
3788 Hinami, Togitsu,  
Nagasaki, 851-2108 Japan  
TEL: 81-95-882-1925 FAX: 81-95-881-0177  
[www.bisoh.co.jp/en](http://www.bisoh.co.jp/en)

NOTE: Contents may change without notice. "Nihon Bisoh" and "BVE" are registered trademarks of Nihon Bisoh Co., Ltd. All copy rights and patents by Nihon Bisoh Co., Ltd.